

Source Four PAR_{Net}™

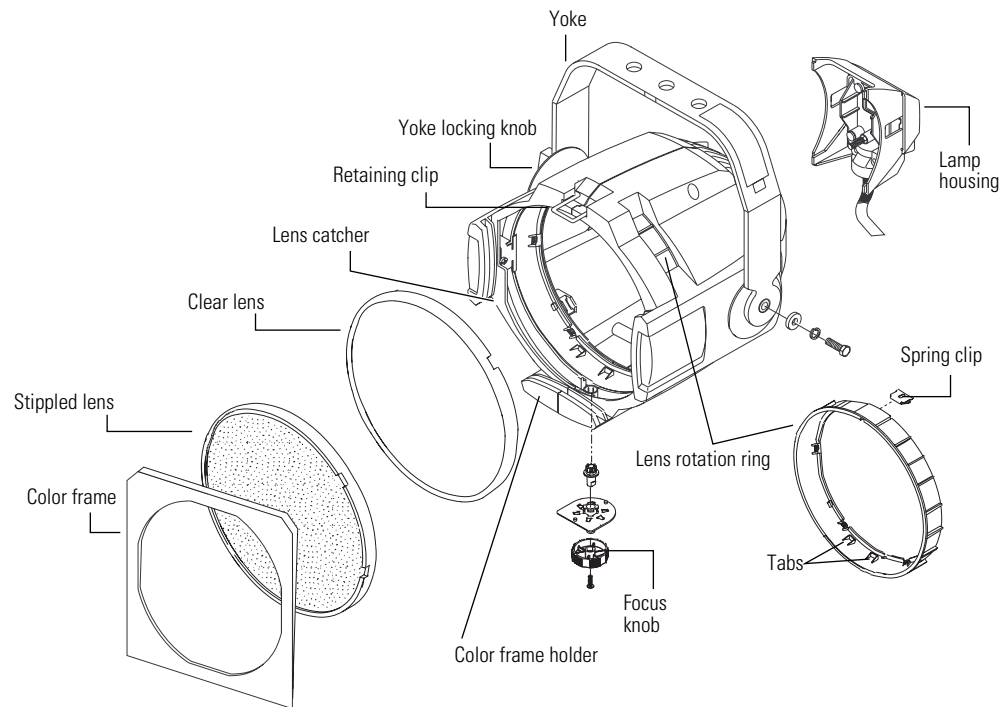

Source Four PAR_{Net}

Please note the following safety warnings before use:

- **Do not** mount the Source Four **PAR_{Net}** on or near combustible surfaces.
- **Do not** operate the Source Four **PAR_{Net}** without a lens installed.
- Always hang the Source Four **PAR_{Net}** with the color frame retaining clip in the locked position.
- Use only HPL lamps of rated wattage. Use of lamp other than approved HPL type will void agency approval and product warranty.

Accessories

Color frame 7.5 in. sq./6.7 in. inside diameter)	407CF
Safety cable (31 in.)	400SC
C-clamp	400CC
Wave/stippled lens	400WS
Wave/clear lens	400WC
Top hat, 3"	400PTH3
Top hat, 6"	400PT6
Half hat	400PHH
Cross-baffle top hat	400XBTH
Gell extender, 3"	400PGE3
Gell extender, 6"	400PGE6
Barn door	400BD
Egg-crate louver	400L
Weighted base	400WB



HPL lamps

Use the HPL lamp only in Source Four and Source Four **PAR**Net fixtures manufactured and sold by Electronic Theatre Controls, Inc. **Do not** use lamps other than the HPL in Source Four **PAR**Net fixtures.

Lamp code	Watts	Volts	Initial Lumens	Color temp.	Average rated life
HPL 750/115	750	115	21,900	3,250° K	300 hour
HPL 575/115	575	115	16,520	3,250° K	300 hour
HPL 575/115X	575	115	12,360	3,050° K	2,000 hour
HPL 575/120	575	120	16,460	3,250° K	300 hour
HPL 375/115	375	115	10,540	3,200° K	300 hour
HPL 375/115X	375	115	8,068	3,000° K	1000 hour
HPL 550/77*	550	77	16,170	3,250° K	300 hour
HPL 550/77X*	550	77	12,160	3,050° K	2,000 hour
HPL 750/220	750	220	19,400	3,200° K	300 hour
HPL 750/230	750	230	19,400	3,200° K	300 hour
HPL 750/240	750	240	19,400	3,200° K	300 hour
HPL 575/230	575	230	14,900	3,200° K	400 hour
HPL 575/240	575	240	14,900	3,200° K	400 hour
HPL 575/230X	575	230	11,780	3,050° K	1500 hour
HPL 575/240X	575	240	11,780	3,050° K	1500 hour
HPL 375/230X	375	230	7,800	3,050° K	1000 hour
HPL 375/240X	375	240	7,800	3,050° K	1000 hour

Table 1: HPL lamp reference

*To be used with ETC Dimmer Doubler™

Installing the HPL lamp

Always replace the lamp if it becomes damaged or deformed.

Verify that the HPL lamp you use is suitable for the voltage at your facility. 115, 120, 230, and 240 volt HPL lamps are available.

Caution! Operating lamps above their rated voltage reduces lamp life and can cause premature lamp failure.

1. Disconnect the unit from power before installing the lamp.

WARNING! Let lamp cool before changing.

2. Loosen the knurled bolt on the back of the lamp housing and pull the housing straight out from the back of the fixture.
3. Remove the HPL lamp from its box, holding it by the base.

Note: To avoid premature lamp failure, do not touch the lamp glass with your fingers. If you touch the lamp during installation, clean it carefully with rubbing alcohol and a clean, lint-free cloth before operation.

4. Line up the flat sides of the lamp base with the brackets on either side of the socket (**Figure 1**).
5. Push down on the lamp base until the lamp is firmly seated. Make sure that the lamp is fully seated, with the bottom of the lamp heat sink flush to the lamp housing casting.

Caution! Improperly installed lamps cause premature lamp failure and socket problems.

6. To reinstall the lamp housing, center it on the reflector and the bolt hole, then tighten the knurled bolt to secure the lamp housing in place.

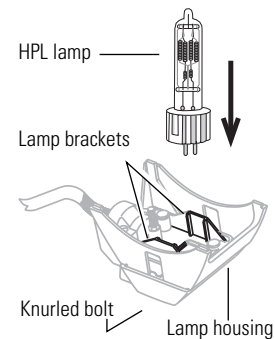
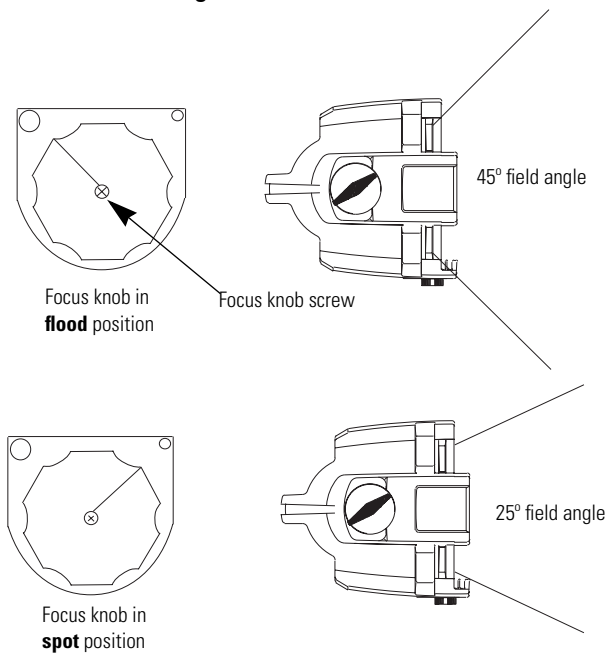

Figure 1

Focus Knob Positioning



Note: To adjust the Focus knob tension, loosen or tighten the Focus knob screw.

Caution! Lens rotation knob does not rotate 360°. Do not attempt to exceed rotational limit.

Lens identification

The Source Four **PAR**Nel comes equipped with two types of lenses; Wave/Stippled (WS) and Wave/Clear (WC). The type can be identified by the lens texture.

Note: The WC rear lens is in a "fixed" position inside the fixture. The WS lens is in the rotating ring at the front of the fixture. The wave surfaces face each other.

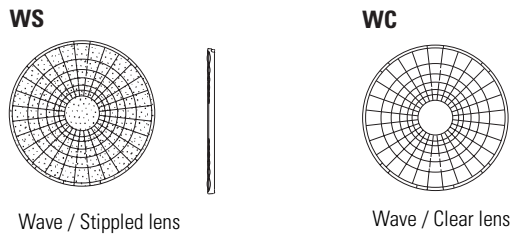

Color frame retaining clip

The color frame holder is equipped with a spring-loaded retaining clip that prevents color frames and accessories from falling out.

WARNING! Hang the Source Four **PAR**Nel with the color frame retaining clip in the locked position.

1. Release the retaining clip by pushing it sideways. The retaining clip opens.
2. Insert the color frame.
3. Press the retaining clip down until it locks.

Note: Use only color frames or top hats with 6.7-inch inside diameter.

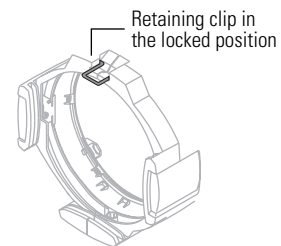

Figure 2

